

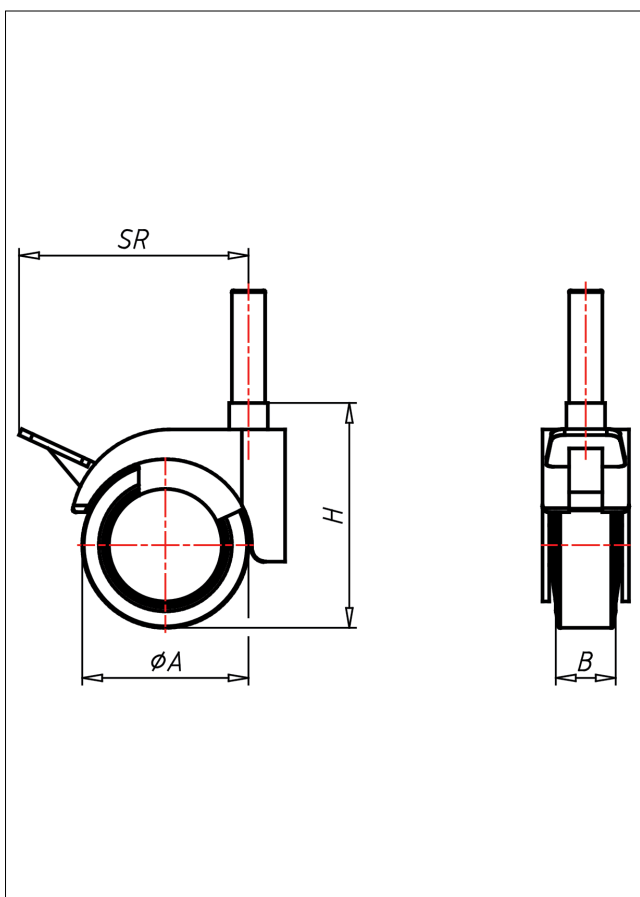

# 476 G

## Lenkrolle mit Radfeststeller



475-G



+60 °C  
-20 °C

max.  
40 kg



Gehäuse: Zinkdruckguss - verchromt  
Schwenklager mit kombiniertem  
Gleit- Kugellager  
Felge Polyamid 6  
grauer Gummireifen - spurfrei  
Radfeststeller glasfaserverstärkt  
Radachse verschraubt

### Technische Details

ORDERNO (Artikel-nummer)	476 11x22 50 G
WDAB (Rad-Ø A x Breite B / mm)	50x18
LC (Tragkraft / kg)	40
H (Bauhöhe H / mm)	68
BOLT (Stift / mm)	11x22
SR (Schwenkradius / mm)	70
WB (Radlager)	Polyamid-Gleitlager